



## Cetetherm AquaTank

ENAMEL (7 BAR)

**Domestic hot water storage tank, 300-3000 litres**

### APPLICATIONS

Cetetherm AquaTank EM is a range of enamel (glass lined) Domestic Hot Water (DHW) storage tanks from 300 - 3000 litres. These tanks are designed for use in combination with Cetetherm's tap water systems like AquaFirst, AquaEfficiency, AquaProtect or AquaCompact. Ideal for any premises where the water flow need is not constant such as in:

- apartment blocks
- hospitals
- hotels
- retirement and nursing homes
- schools
- leisure centres...

### KEY BENEFITS

- Robust and good value for money
- Easy maintenance thanks to tanks' polished inside surface
- High resistance to any chemicals and to high temperatures
- Energy saving insulations with high level of fireclass
- Sanitary conformity of materials in contact with DHW
- Easy to install

### WORKING PRINCIPLE

The AquaTank acts as a buffer to meet the power peaks occurring at high water flow rates. The Domestic Hot Water (DHW) - heated up by the connected tap water system - is stored at the top of the vessel. The specific AquaTank internal

tube arrangement keeps the hot water separated from the recycling and cold water inlet and improves stratification during peak hours. The cold water inlet at the very bottom of the tank (see flowchart) avoids having a zone of stagnant cold water inside the vessel. When high demand occurs, hot water is drawn from the bottom to the centre and from the centre to the very top of the vessel.

### INSULATION

The enamel AquaTank range is available with 2 types of insulation:

- M1 insulation: 100 mm polyester fiber covered with a PVC-jacket, Eurofire class B
- Pre cut delivered with finishing rosettes
- M0 insulation: 100 mm rockwool covered with an aluminium-plate cladding, Eurofire fireclass A
- Conform to the EU directive of energy efficiency (see technical data).
- Extremely low heat losses thanks to the special design of the insulation avoiding the so-called "chimney-effect" between insulation and vessel surface (see technical data).
- Very easy to remove and refit makes this vessel easy to transport into and out of premises.

### FLEXIBLE ENERGY SOURCE

The complete AquaTank Enamel range is able to accept electric immersion heaters. These immersion heaters can be installed on the inspection holes in a very simple way.

## DRAWING

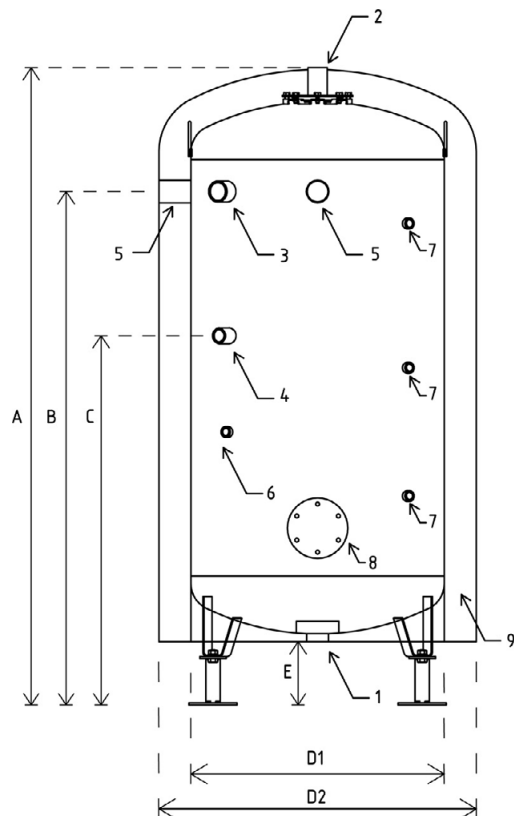

### Connections (see table for sizes)

1. Cold water inlet with specific stratification feature
2. Hot water outlet
3. Heat exchanger charge inlet
4. Hot water recirculation inlet
5. Two added Rp 2" connections for extra inlet or safety valve installation (not proposed on 2500 and 3000 litres enamel tank)
6. Rp 3/4" added sensor connection on all the range except on 2500 and 3000 litres enamel tank where an added Rp 2" on the bottom of the vessel, is proposed instead
7. Two or three anodes available depending on the volume of the tank
8. Visit or manhole opening
9. 100 mm glasswool (M1) or rock wool (M0) insulation

## TECHNICAL DATA

Volume (L)	Inspection opening (mm)	Insulation (100 mm)	Dimensions* (mm)						Connections 1/2/3/4	ErP ** classe	Heat loss coefficient UA (W/K)	Weight (kg)	Article no.
			A	B	C	E	D1*	D2*					
300	110	M1	1515	1395	966	216	630	830	2" / 2" / 2" / 1"	B	1,35	110	AQT030EB1100
500	110	M1	2143	1748	959	198	630	830	2" / 2" / 2" / 1"	C	1,3	137	AQT050EB1100
750	110	M1	2047	1601	1151	197	790	990	2" / 2" / 2" / 1"	C	1,6	200	AQT075EB1100
	400	M1										243	AQT075EC1100
	110	MO	2037	260	AQT075EB0100								
	400	MO		293	AQT075EC0100								
1000	110	M1	2400	1954	1324	197	790	990	2" / 2" / 2" / 1"	C	1,9	263	AQT100EB1100
	400	M1										263	AQT100EC1100
	110	MO	2390	293	AQT100EB0100								
	400	MO		320	AQT100EC0100								
1500	110	M1	2226	1700	1250	221	1100	1300	2" / 2" / 2" / 1"	C	2,15	344	AQT150EB1100
	400	M1										390	AQT150EC1100
	110	MO	2216	384	AQT150EB0100								
	400	MO		480	AQT150EC0100								
2000	400	M1	2414	1888	1258	221	1100	1300	2" / 2" / 2" / 1"	C	2,2	420	AQT200EC1100
	400	MO	2404									520	AQT200EC0100
2500	400	M1	2245	1680	1180	215	1400	1600	2" / 2" / 2" / 2"	E	2,8	556	AQT250EC1100
	400	MO										660	AQT250EC0100
3000	400	M1	2374	1810	1245	215	1400	1600	2" / 2" / 2" / 2"	E	3,2	560	AQT300EC1100
	400	MO										665	AQT300EC0100

\* Dimensions are target values. Binding figures are shown on the drawings.

**D1** = outside diameter of the tank without insulation /

**D2** = outside diameter of the tank with insulation

\*\* EN 12897: 2006

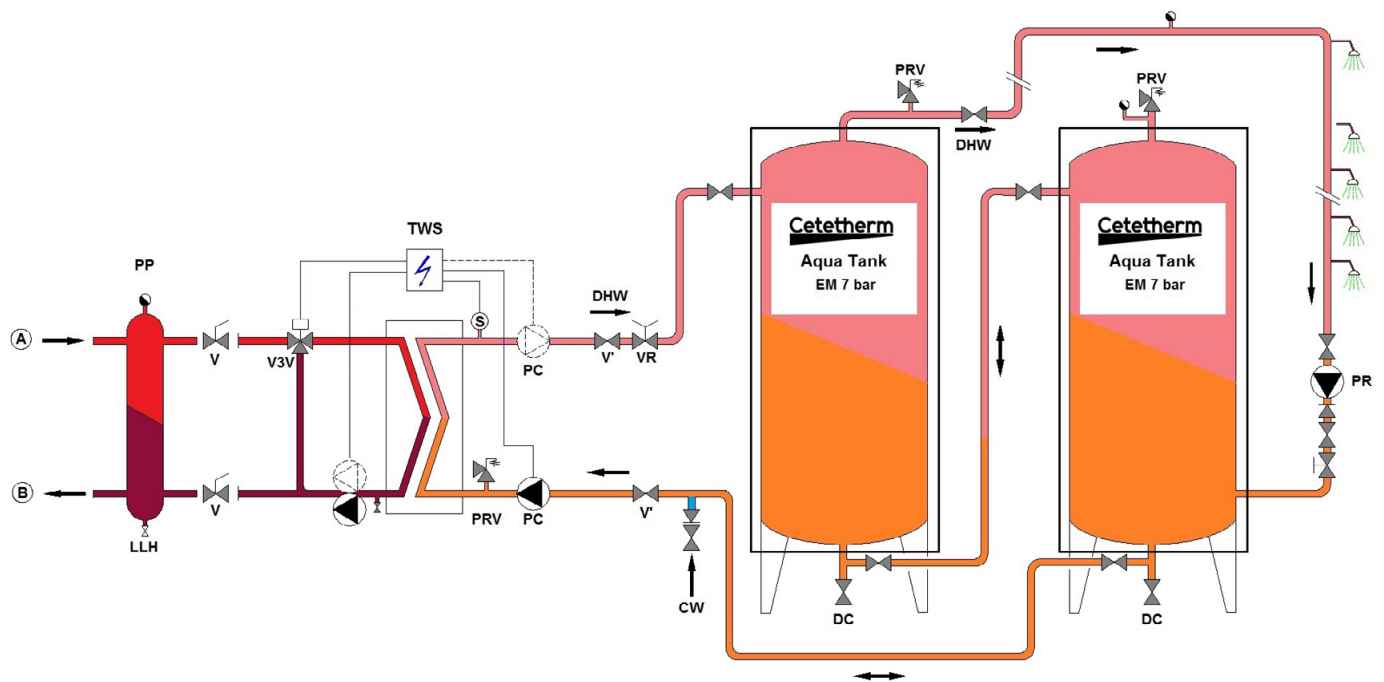
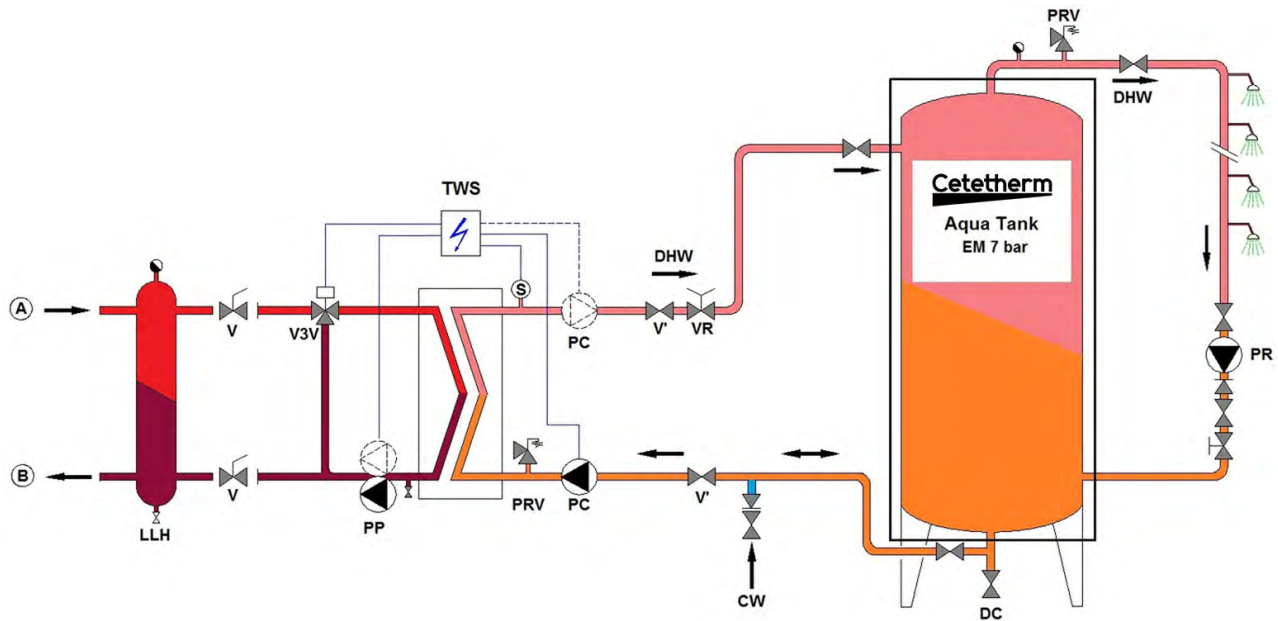

- |     |                                 |     |   |
|-----|---------------------------------|-----|---|
| A   | Primary inlet                   | PR  | Recycling pump (on installation)          |
| B   | Primary outlet                  | PRV | Pressure relief valve                     |
| CW  | Cold water inlet                | S   | DHW temperature sensor                    |
| DC  | Draining valve                  | TWS | Tap Water System                          |
| DHW | Domestic Hot Water              | V   | Manual gate valve                         |
| HE  | Heat exchanger (PHE)            | VR  | Balancing valve                           |
| PC  | Charging pump (one or two)      | V3V | Mixing 3-port control valve with actuator |
| PP  | Primary pump (single or double) |     |   |

Operating limits	
Maximum operating pressure (gauge)	7 bar
Maximum operating temperature	95°C