

Optimized solution for hot water system in combination with heat pumps for collective applications



&



A DOMESTIC HOT WATER MODULE IN COMBINATION WITH HEAT PUMPS

Cetetherm AquaEfficiency Neo is a domestic hot water module, heating the hot water instantaneous. All accumulation is on the primary side, hence no need for storage tanks with any corrosion protection. The best economic and hygienic energy storage solution.

The unique set point controller and well combined components ensure a low return temperature resulting in a high efficiency, COP, for the tap water production.

Cetetherm AquaEfficiency Neo is a ready to install solution with capacity up to 1000kW including primary pump, DHW circulator pump, mixing valve, and controller.

Standard is copper brazed stainless heat exchangers but AquaEfficiency Neo can be delivered with plates and gaskets or all stainless-steel heat exchangers.

Energy efficient – domestic water production with high COP

Optimized hot water circulation, DHW – very low temperature difference between primary and hot water side.

Economic solution – simple installation, ready to connect and energy storage in tanks without corrosion protection.

Cetetherm AquaEfficiency Neo is intended to be combined with NIBE's heat pumps and buffer tanks. Using flow control on the primary flow will achieve a layered charging of the primary tanks.

AquaEfficiency Neo is equipped with ModBus that will make it possible to control and read from a distance.

FUNCTION

System description

Cetetherm AquaEfficiency Neo produces domestic hot water instantaneous, hence no storage of tap water.

Energy is exchanged through a heat exchanger from the primary to the DHW side. On the primary side, AquaEfficiency Neo is connected to heating source for example NIBE F1345/ F1355 or NIBE F2120 with primary tank.

The flow of the water entering the heat exchanger on the primary side is adapted to meet the demand on the domestic hot water side. The mixing valve eliminates the risk of scalding and reduces the potential build-up of lime-scale on the secondary side.

A DHW circulation pump make sure that there is always hot water with right temperature in the whole circuit.

The primary tanks are connected in series. For higher charging effect can the tanks be connected in parallel batteries to slow down the flow velocity, enabling for a good stratification.

On the primary side is important to install a balancing valve between the tank and heat pump. This is crucial to get a good layering.

Senor BT7 is placed in the top of the tank closest to the heat pump and it controls sensor BT6, placed with 1/3 of the tank volume below its location. That is, with three tanks equally in series, BT6 should be places at the top of the last tank.

DOCKING PRINCIPLE

Docking with one primary tank

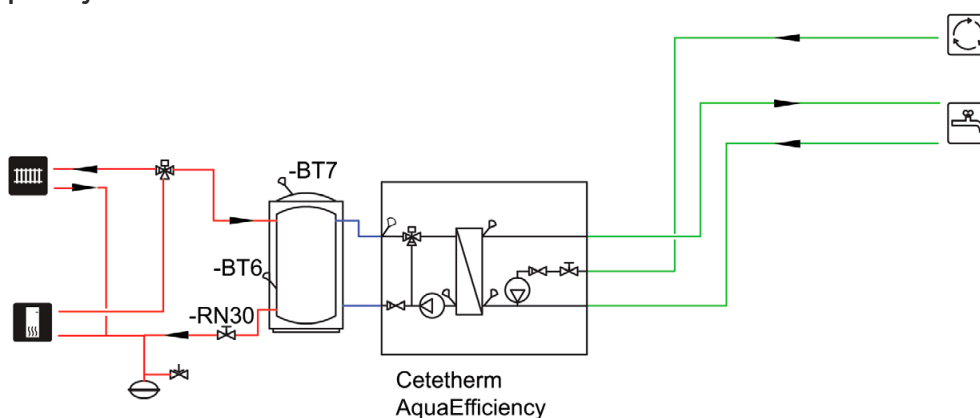

Docking with two primary tanks in series

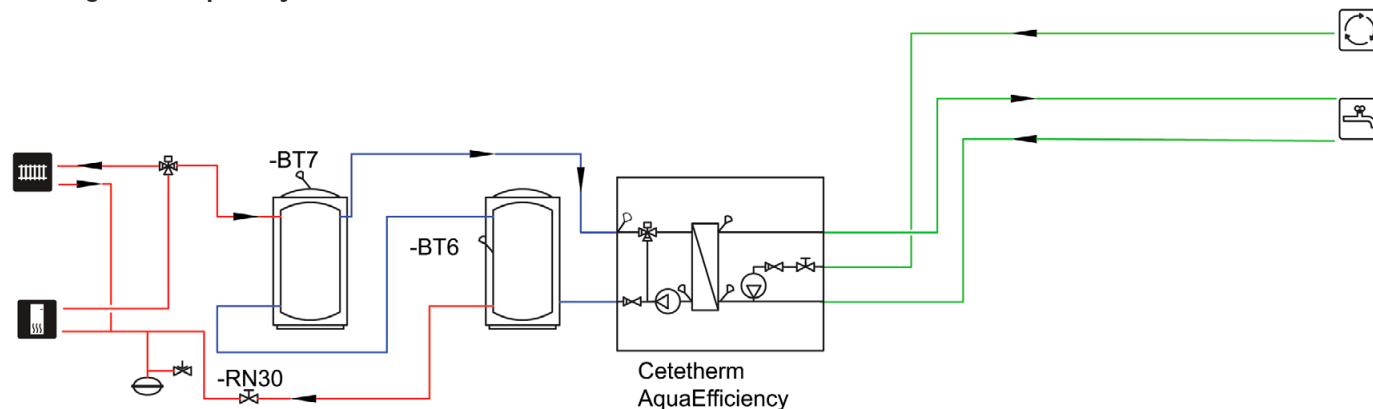

Docking with four primary tanks in two parallel batteries

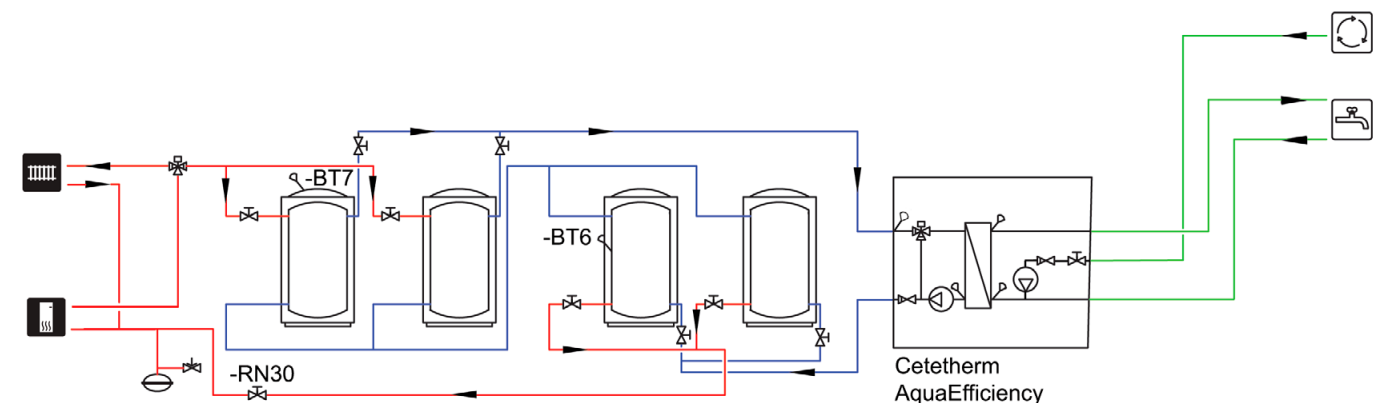

Note! The flow in the blue pipes are higher than in the red pipes.

DESIGN GUIDE

Number of apartments *	AquaEfficiency Neo article number	DHW power [kW] DHW flow $\Delta 45K$ [l/min]	Rec. Tank volume at min. rec heat pump power	Min. rec. Heat pump power **
10-15	EFB6050IS	143 / 45	750	12
20-28	EFB6050IS	205 / 65	1500	15
25-35	EFB6050IS	232 / 74	1750	20
30-41	EFB6080IS	256 / 81	2000	20
35-48	EFB6080IS	279 / 88	2250	30
50-68	EFB11250IS	342 / 109	3000	40
60-82	EFB11250IS	381 / 121	3500	40
70-95	EFB11270IS	418 / 133	4000	60
85-115	EFB11270IS	469 / 149	4500	60
100-143	EFB11230IS	538 / 171	5000	90
110-158	EFB11230IS	570 / 181	6000	90

TECHNICAL DATA

Maximum operating pressure	10 bar
Maximum operating temperature	100 °C
Electrical connections	230V-50Hz
Heat exchanger	Copper brazed stainless
Primary pump	Included

* Min value correspond to apartments with 5-6 rooms and max value to apartments with 1-2 rooms.

** Installed heat pump effect can advantageously be increased.
The use of primary storage of energy enables a high charging power .

Recommended tank volume can be increased with 25% by doubling the heat pump power.
Bigger effects are available on request.

AQUAEFFICIENCY INSTANTEANOUS SINGLE PUMP CB60

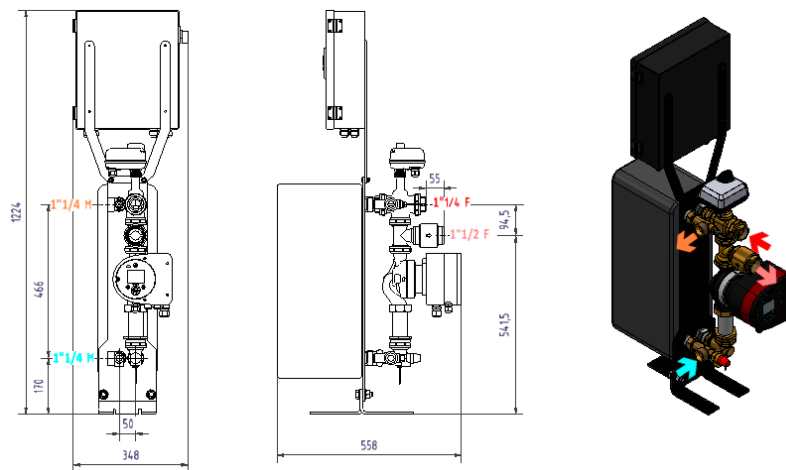

AQUAEFFICIENCY INSTANTEANOUS SINGLE PUMP CB112

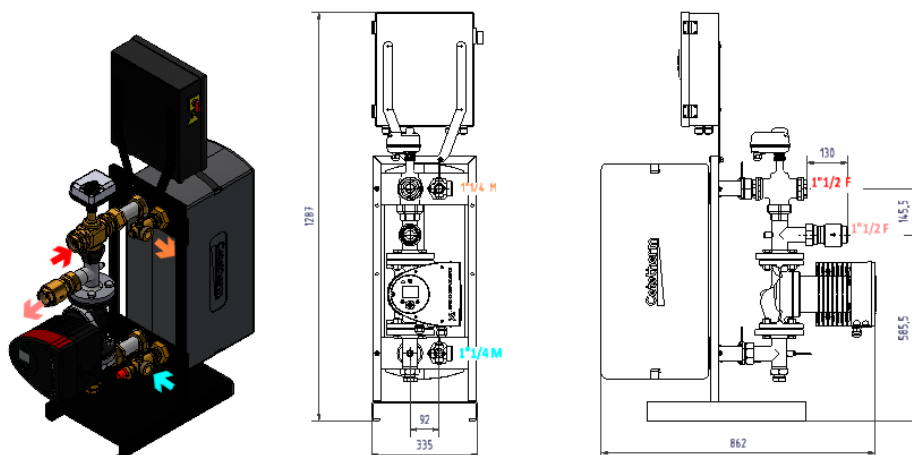

SETTING NIBE HEAT PUMP

Setting the primary flow

For example, a NIBE F1345/F1355 or NIBE F2120 with control system SMO40.

Good stratification is an enabler to get the highest efficiency and the best use of the primary tanks. Therefore, is it important to adjust the primary flow.

NIBE F1345/F1355 – setting the primary flow

See menu 5-Service.

In menu 5.1.11 Heating medium pump speed, set the «operation mode hot water» to « manual» and « manual settings hot water» to «100%».

Wait until all compressors, connected to domestic hot water, have started.

Adjust the flow with the balancing valve (-RN30) that the difference between supply and return line are 10K, at approx. 55 °C supply (10,5K at 45 °C and 11K at 35 °C supply).

Let the system stabilize for 3 minutes after adjusting the balancing valve, before making any new adjustments. After 10 minutes operation, verify the correct temperature difference.

When the correct temperature difference has been verified, see menu 5.1.10–operation mode heating medium pump and set «operation mode, hot water» to «intermittent» or «auto» depending on docking principle. In menu 5.1.1 hot water settings set «charging method» to « target temp».

NIBE F2120 with SMO40 – setting the primary flow

See menu 5-Service.

In menu 5.11.X.2 charging pump set « speed at hot water operation» to «manual» and « manual settings» to «100%» for each slave.

In menu 5.1.23-Compressor curve, choose «hot water» check out «auto» and configure the highest possible compressor curve to ensure that the hot water is always made at max compressor frequency.

Wait until all compressors, connected to domestic hot water, have started.

Adjust the flow with the balancing valve ('RN30) according to diagram.

Let the system stabilize for 3 minutes after adjusting the balancing valve, before making any new adjustments. After 10 minutes operation, verify the correct temperature difference.

When the correct temperature difference has been verified, see 5.11.X.2 charging pump set « speed at hot water operation» to «intermittent» or «auto» depending on docking principle. In menu 5.1.1 hot water settings set «charging method» to « target temp».

Setting temperature hot water charge with NIBE F1345/F1355 and NIBE SMO40

Activate start and stop of hot water charging in menu 5.1.1-hot water settings. If desired tap water temperature is 55 °C it is recommended that the normal setting for stop is 59 °C and start is 53 °C.

Step difference compressors set to 0 °C.

START SETTINGS FOR AQUAEFFICIENCY NEO

NOTE! AquaEfficiency Neo must not be started until the temperature at temperature sensor (BT7) has reached 60 °C

When starting up AquaEfficiency Neo set the time and date, this is done in the «Home» menu.

Operating mode and number of pumps must be set. Login to «Configuration menu». See manual for password.

Go to menu «Configuration» and set the following parameters:

- Operation mode PREMIUM
- Pump 1 activated
- Pump 3 activated

Set hot water setpoint in menu «S1 Actual setpoint», parameter «S1 setpoint». Recommended setting is 55 °C.

