



Cetetherm Mini Plus



District heating substation for single-family houses and multi-family buildings

The Cetetherm Mini Plus district heating substation is ready for installation to meet the complete central heating and hot water requirements. It can be used for single-family houses or multi-family buildings (1-12 dwellings).

Cetetherm has many years of experience in district heating technology, which is put to expert use in the Mini Plus, resulting in its practical function and ease of use. All components are easily accessible for inspection and future service when required.

HIGH COMFORT

The Mini Plus has a fully automatic individual temperature setting for central heating and hot water. Heat is automatically regulated, depending on outdoor temperature and the desired temperature inside the building. Domestic hot water is heated completely separately in a high-capacity heat exchanger, thus ensuring that the hot water is always as fresh as the incoming cold water from the main supply.

SIMPLE INSTALLATION

Compact dimensions, lightweight, well-planned pipe runs and factory-installed interior electrical routing all make installation very simple. A pre-programmed controller simplifies commissioning and allows immediate start-up. In addition, the pipes can be connected up or down depending on the layout of the building.

LONG-TERM SECURITY

The Mini Plus represents the most modern technology and provides the answer to stringent demands for long-term performance. The heat exchanger plates and all piping are manufactured in acid-resistant stainless steel.

All components are closely matched and carefully tested to function in accordance with quality assurance system ISO 9001:2008. The Mini Plus is CE-marked to certify that the substation conforms to international safety regulations.

DISTRICT HEATING - AN EXCELLENT HEATING METHOD

District heating is an efficient technology that satisfies the need for central heating and hot water in a simple, convenient and secure way. The expansion of district heating to its current level has reduced emission of greenhouse gases from heating by about 20%. The financial aspects of district heating are very competitive compared with other forms of heating.

OPERATION

The incoming hot medium from the district heating underground network is at very high pressure and temperature. Therefore, only the heat from this is used; the district heating medium does not mix with the water in the heating and hot water system in the building. Heat exchangers are used to transfer heat from the district heating medium to the water in the dwelling's central heating and hot water system.

Heat is transferred through a package of thin acid-resistant, stainless steel plates, which keep the district heating medium completely separate from the building's own system.

Mini Plus has automatic temperature control for central heating and hot water. The heating circuit is adjusted in relation to the outdoor temperature and the required indoor temperature via a thermostatic control and outdoor temperature sensor. When no heating flow is required, the heating circulation pump stops automatically, but is run occasionally to prevent seizing up due to long standstill.

An automatic temperature regulator controls the hot water temperature. This measures the temperature of the hot water in the heat exchanger and automatically adjusts the outgoing flow.

The district heating utility company registers use of energy. Measurement is done by recording the flow of the district heating medium through the system and by measuring the temperature difference between the medium's supply and return flow.

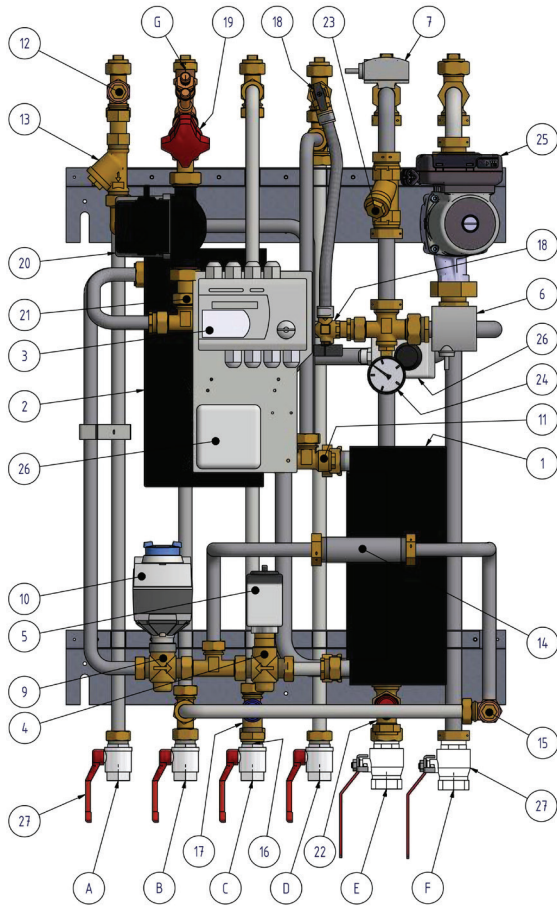

COMPONENTS

1. Heat exchanger for heating
 2. Heat exchanger for domestic hot water
 3. Operator control panel with connection box
 4. Control valve, heating circuit
 5. Actuator, heating circuit
 6. Supply temperature sensor, heating circuit
 7. Return temperature sensor, heating circuit
 8. Outdoor temperature sensor
 9. Control valve for domestic hot water
 10. Actuator, domestic hot water
 11. Supply temperature sensor, domestic hot water
 12. Temperature sensor connection, district heating supply
 13. Filter for district heating supply
 14. Adapter for energy meter
 15. Temperature sensor connection, district heating return
 16. Check valve for cold water
 17. Safety valve for domestic hot water
 18. Topping-up heating
 19. Balancing valve DHWC
 20. Circulation pump for DHWC
 21. Check valve for DHWC
 22. Safety valve for heating circuit
 23. Filter for heating circuit
 24. Pressure gauge for heating circuit
 25. Circulation pump for heating circuit
 26. Safety thermostat (option)
 27. Shut-off valve
- A. District heating media, supply
 B. District heating media, return
 C. Cold water
 D. Hot water
 E. Heating circuit, return
 F. Heating circuit, supply
 G. Domestic hot water circulation

Brass components are of dezincification-resistant quality. Connections for district heating and tap water DN20, internal threading. Connections for heating DN25, internal threading. The pipes can be connected up and/or down. Shut-off valves are included and come with the delivery.

DIAGRAMMATIC FLOW CHART FOR MINI PLUS

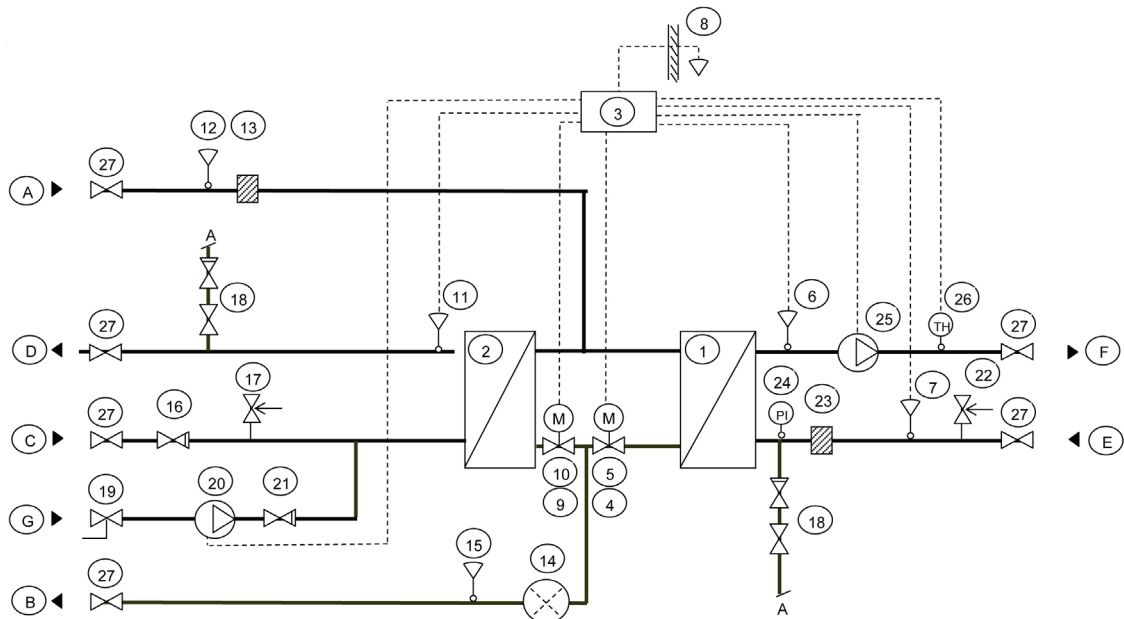

OPERATING DATA

	Heating medium	Heating circuit	Hot water circuit
Design pressure, MPa	1.6	1.0	1.0
Design temperature, °C	120	90	90
Opening pressure, safety valve, MPa	-	0.25	0.9
Volume, l	1.01/1.47	1.05	1.62

PERFORMANCE AT AVAILABLE PRIMARY DIFFERENTIAL PRESSURE 100-600 KPA

Designed temperature programme (°C)	Capacity (kW)	Primary flow (l/s)	Actual return temp. (°C)	Secondary flow (l/s)
Hot water circuit				
70-25/10-58	100	0.48	20	0.50
65-22/10-55	113	0.63	22	0.60
65-22/10-55	82	0.43	20	0.43
Heating circuit UPML 25-95 pump				
100-63/60-80	58	0.39	63.00	0.71
100-53/50-70	60	0.31	52.10	0.73
100-33/30-37	21	0.07	30.03	0.72
Heating circuit UPM3 15-70 pump				
100-63/60-80	53	0.35	62.70	0.64
100-53/50-70	53	0.27	51.30	0.64
100-33/30-37	19	0.07	30.82	0.64

CONNECTIONS

	Screws
District heating media supply	G ¾"
District heating media return	G ¾"
Heating circuit supply	G 1"
Heating circuit return	G 1"
Cold water	G ¾"
Hot water	G ¾"

OTHER INFORMATION

Electrical data: 230 V, 1-phase, 120 W
Dimensions: 590 mm width x 400 mm depth, 990 mm height
Weight: 33 kg
Transport particulars: Total weight 40 kg, 0.4 m ³

AN EASILY MANAGEABLE, ECONOMICAL AND DURABLE SOURCE OF HEAT

The Mini Plus uses the hot district heating medium for heating domestic hot water (providing an uninterrupted supply) as well as the water in the central heating system.

The Mini Plus is a wall-hung unit and is very compact and discreet. To minimize transmission of operational noise we recommend installing it on well insulated walls or on walls of concrete.

Mini Plus requires no attendance or maintenance and has a very long operational life. In the event service is required or components need to be exchanged at some future date, all parts are easily accessible and individually replaceable.