

## Cetetherm AquaTank

### 316Ti 10BAR



Domestic Hot Water storage tank,  
300-4000 litres

#### APPLICATIONS

Cetetherm AquaTank 316Ti is a range of stainless steel secondary storage tanks from 300 - 4000 litres. These tanks are designed for use in combination with Cetetherm's tap water systems like AquaFirst, AquaEfficiency, AquaProtect or AquaCompact. Ideal for any premises where the water flow need is not constant such as in:

- apartment blocks
- hospitals
- hotels
- retirement and nursing homes
- schools
- leisure centres...

#### KEY BENEFITS

- Best quality for 10bar applications
- Extremely hygienic: no galvanic corrosion
- Energy saving insulation
- Very long lifetime
- Possibility to add electric immersion heaters

#### WORKING PRINCIPLE

The AquaTank acts as a buffer to meet the power peaks occurring at high water flow rates. The Domestic Hot Water (DHW) - heated up by the connected tap water system - is stored at the top of the vessel. The specific AquaTank internal tube arrangement keeps the hot water separated from the

recycling and cold water inlet. The cold water inlet at the very bottom of the tank (see flowchart) avoids having a zone of stagnant cold water inside the vessel. When high demand occurs, hot water is drawn from the bottom to the centre and from the centre to the very top of the vessel.

#### INSULATION

- The energy saving insulation is made of Neodul and the surface is covered with an impact-resistant polyester hard plastic (see technical data).
- Conform to the EU directive of energy efficiency and conform to Eurofire class (see technical data).
- Extremely low heat losses thanks to the special design of the insulation avoiding the so-called "chimney-effect" between insulation and vessel surface (see technical data).
- Very easy to remove and refit makes this vessel easy to transport into and out of premises.

#### FLEXIBLE ENERGY SOURCE

The complete range of the Cetetherm AquaTank 316Ti are equipped with threaded connections to give the possibility to add electric immersion heaters. These can be fitted directly to the threaded connections, which simplifies the installation work.

## DRAWING

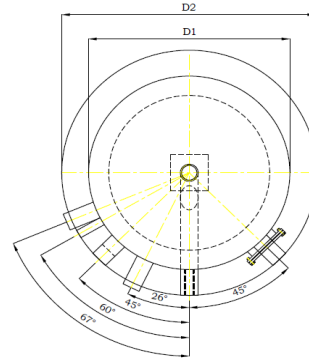
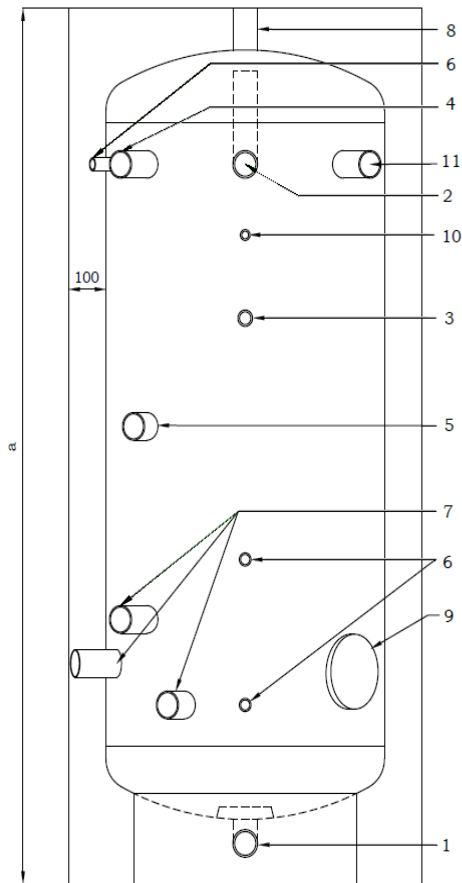

### Connections (see table for sizes)

1. Cold water inlet
2. Hot water outlet
3. Hot water circulation
4. Hot water inlet
5. Support sleeve 2" (300 to 1500 L)
6. Instrument connection, 3/4"
7. Sleeves for immersion heater 2" (300 to 2000 L)
8. Air vent, 2"
9. Inspection opening
10. Instrument connection, 1/2"
11. Safety valve 2" (300 to 2000 L)

Drawing for 300 to 1500 L tanks.  
Above 1500 L please consult.

## TECHNICAL DATA

Tank capacity (L)	Inspection opening (mm)	Dimensions* (mm)			Connections 1, 2, & 3 (inch or DN)	Heat losses (kWh in 24 h)	Weight (kg)	Number of sleeves for imm. heater(s)	Article number
		a	D1*	D2*					
300	120	1560	550	750	2" / 2" / 1"	1.58	68	1	AQT030SB4U
500	120	1815	650	850	2" / 2" / 1"	2.36	91	2	AQT052SB4U
750	120	2105	750	950	2" / 2" / 1"	2.89	146	2	AQT075SB4U
1000	120	2180	850	1050	2" / 2" / 1"	3.36	200	3	AQT100SB5U
1000	400	2180	850	1050	2" / 2" / 1"	3.52	198	3	AQT100SC5
1500	400	2245	1000	1240	2" / 2" / 1"	3.89	299	3	AQT150SC5U
2000	400	2545	1100	1340	DN50 / DN50 / 1 1/4"	4.31	348	3	AQT200SC5U
2500	400	2410	1300	1540	DN50 / DN50 / 1 1/4"	-	475	-	AQT250SC5
3000	400	2910	1300	1540	DN50 / DN50 / 1 1/4"	-	555	-	AQT300SC5
4000	400	3660	1300	1540	DN50 / DN50 / 1 1/4"	-	665	-	AQT400SC5

\* Dimensions are target values. Binding figures are shown on the drawings

**D1** = Tank's outside diameter without insulation

**D2** = Tank's outside diameter insulation included

Please consult for electric immersion heaters option

## INSULATION CHARACTERISTICS

- Eurofire class D S1, do/EN 13501-1 (or B2 / DIN4102)
- 300 to 1000L: Neodul 80/20 (100mm) covered with a polyester hard plastic
- 1500 to 4000L: Neodul 100/20 (120mm) covered with a polyester hard plastic
- Energy efficiency class according to European Union rule N°814/2013 and N°812/2013:
  - 300L: energy efficiency class B
  - 500 to 2000L: energy efficiency class C
  - 2500 to 4000L: not mandatory

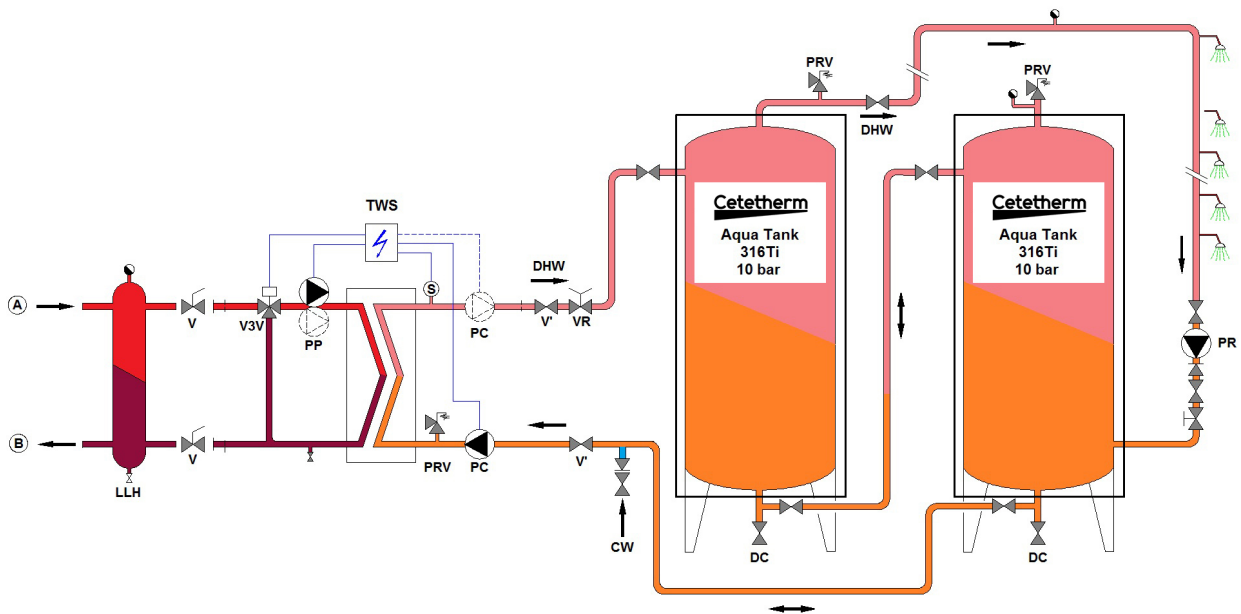
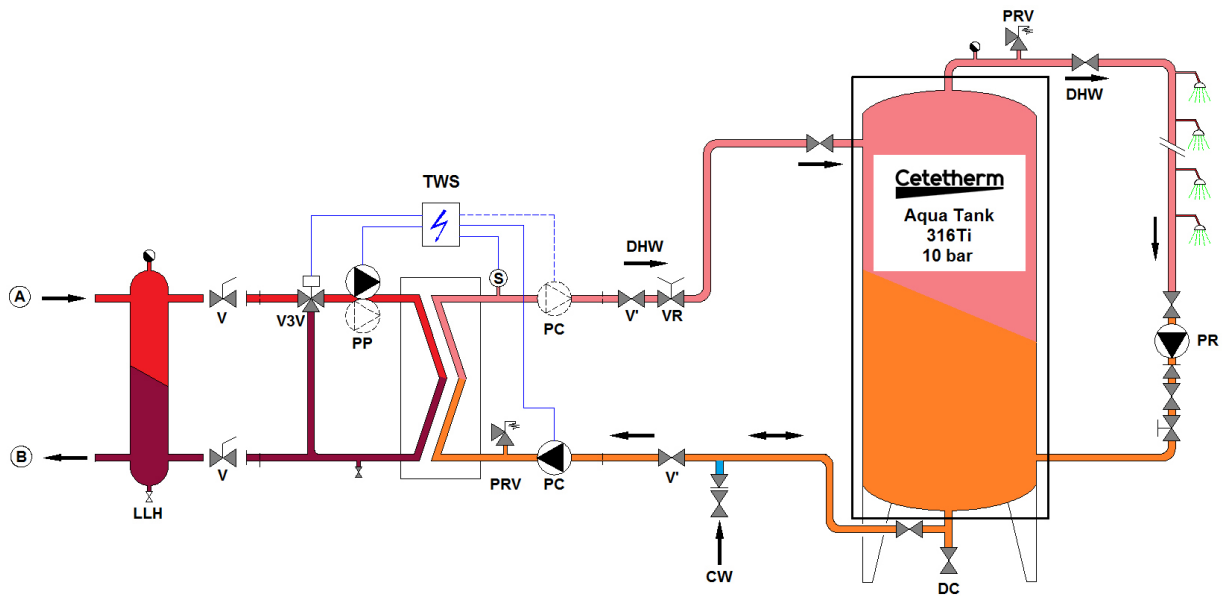

- |     |                                 |     |   |
|-----|---------------------------------|-----|---|
| A   | Primary inlet                   | PR  | Recycling pump (on installation)          |
| B   | Primary outlet                  | PRV | Pressure relief valve                     |
| CW  | Cold water inlet                | S   | DHW temperature sensor                    |
| DC  | Draining valve                  | TWS | Tap Water System                          |
| DHW | Domestic Hot Water              | V   | Manual gate valve                         |
| HE  | Heat exchanger (PHE)            | VR  | Balancing valve                           |
| PC  | Charging pump (one or two)      | V3V | Mixing 3-port control valve with actuator |
| PP  | Primary pump (single or double) |     |   |

Operating limits	
Maximum operating pressure (gauge)	10 bar
Maximum operating temperature	95°C